



APPLICATION NOTE

An In-Depth Examination of an Energy Efficiency Technology

Efficiency Improvements in Industrial Compressed Air Systems

Summary	1
How This Technology Saves Energy	2
Types of Efficiency Improvements.....	3
Applicability	7
Field Observations to Assess Feasibility	7
Estimation of Energy Savings	8
Cost and Service Life	8
Laws, Codes, and Regulations.....	9
Definitions of Key Terms	9
References to More Information.....	9
Major Organizations	10

Summary

Compressed air systems are among the most common industrial electrical end uses. Large compressors, frequently 100 to 1,000 horsepower or more, supply air for manufacturing processes, or to power equipment such as conveyers, grinders, jack hammers, drills, aerators, paint sprayers, etc.

Air-powered devices are reliable and have a high power capacity for their relative size and weight, but they are inherently inefficient. Finding opportunities to improve their efficiency becomes a high priority. This Application Note explains why these systems are often inefficient, and introduces typical opportunities for saving energy. Four strategic areas of opportunity are covered:

- Find alternative means of meeting process needs, or *don't use it*.
- Reduce system losses and excessive use, or *use it efficiently*.
- Compressor management and control, or *produce it efficiently*.
- Heat recovery, or *recoup your losses*.

How This Technology Saves Energy

Compressed air systems typically consist of one or more compressors connected to distribution piping throughout a plant, plus equipment to condition the compressed air (e.g., filter and dry it), to regulate its pressure, and to store it. At the final point of use, the compressed air may be used directly in a process, or used by equipment such as paint sprayers, conveyers, grinders, jack hammers, drills, aerators, etc. Figure 1 shows some components of a typical system.

It is helpful to view a compressed air system as a “power utility.” As compressed air expands, its potential energy is used to perform work in the plant or

process. But because the compression of air results in a substantial temperature rise, most of the potential pneumatic energy is dissipated as heat when the air cools to a usable temperature. Less than 10-20 percent of the energy input to the system is available for use at the air tool or process. Thus reducing unnecessary compressed air usage is a high priority energy-efficiency strategy.

Energy savings opportunities fall into four categories:

- **Alternate Means:** There may be more efficient ways to meet the need, such as electric or hydraulic tools, or high-volume, low-pressure blowers.
- **Reduce System Losses and Excessive Use:** Includes operating at the most efficient pressure and reducing air

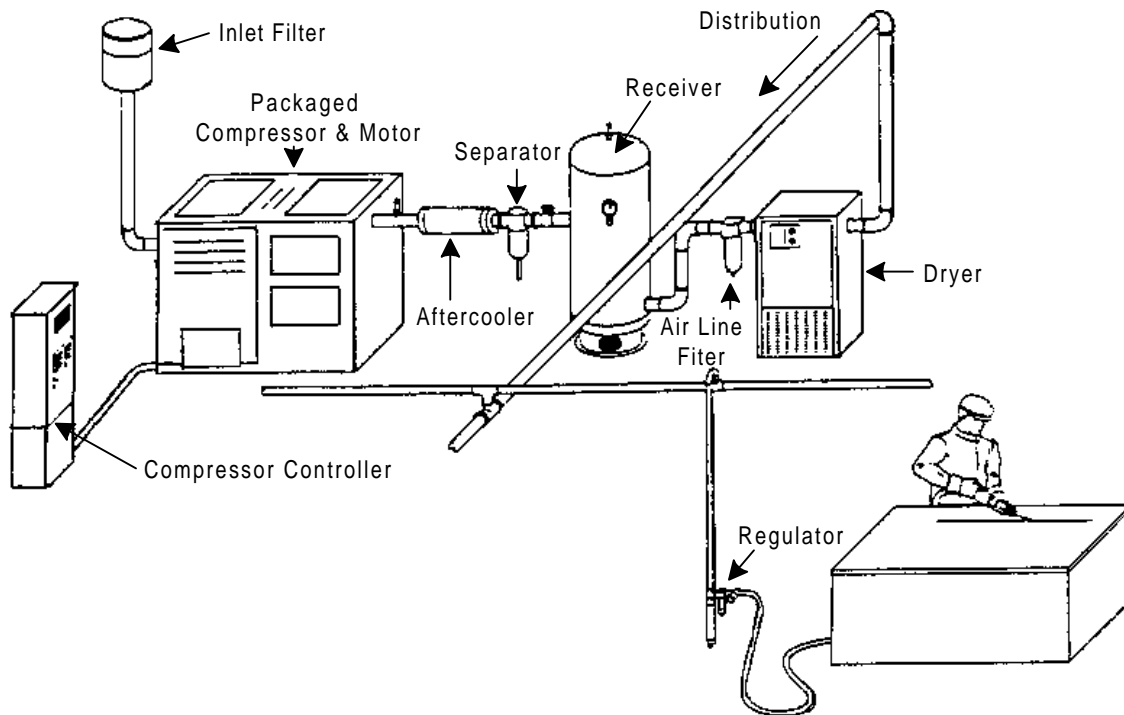

Figure 1: Typical Compressed Air System (Copyright 1994. Electric Power Research Institute. EPRI CR-104546. Reprinted with permission.)

leaks and pressure losses throughout the system.

- **Compressor Management and Control:** Includes efficient part-load control techniques for compressors, and management of multiple compressors in the same system.

- **Heat Recovery:** Includes recovering waste heat from compressors and after-coolers for use elsewhere in the plant.

Types of Efficiency Improvements

Alternate Means of Meeting Process Need (Don't use it!)

Compressed air is often used because it is believed to be convenient, safe, and labor-saving. These advantages may outweigh its high cost, but often its energy impact is completely overlooked. Here are some strategies that can be employed in lieu of high-pressure compressed air:

- **Use fans or blowers** for drying parts, cooling employees, or cleaning debris.

- **Mechanical stirrers or low-pressure air** can sometimes be used for agitation, mixing chemicals, or aeration in non-explosive environments.

- **Provide a vacuum pump** or vacuum system instead of a *venturi*¹.

¹ Bold-Italic words are defined in the section titled Definition of Key Terms.

- **Use brushes to clean** debris and sweep the floor.

- **Use electrical or hydraulic tools** if appropriate. Pneumatic tools provide more torque with less weight and better speed control, but generally cost much more to operate.

Reduce System Losses and Excessive Use (Use it efficiently!)

Air leaks, improper pressure regulation, and airflow restrictions can easily reduce the useful *capacity* of a system 50 percent or more. The usual "solution" is to add a new compressor, when fixing the problem would be much more cost effective and energy efficient. Following are some ways to improve efficiency of a compressed air system:

Leak Reduction Program

Leaks are the single greatest source of loss in compressed air systems. Table 1 summarizes the losses at 100 *psig*, the most common pressure level for general industrial applications. Losses in an average plant may amount to 20 percent of total capacity and can go as high as 50 percent. Besides increasing useful capacity and solving pressure problems, fixing leaks is generally a good investment, with paybacks typically measured in months.

Leaks are usually detected by visual inspection (soap suds brushed on joints) or acoustic leak detectors sensitive to the ultrasonic hiss that leaks produce. Fixing the leak may involve repair or replacement of pipe sections, hoses, joints, traps and drains.

Hole Diameter	Wasted Air (Cubic Feet per Year)	Wasted Energy (kWh/ Year)
1/32"	553,000	1,500
1/16"	2,220,000	6,040
1/8"	8,800,000	24,240
1/4"	35,000,000	97,000
3/8"	79,000,000	218,500

Based on continuous operation and sharp hole @ 100 psig.

Table 1: Losses from Compressed Air Leaks

Various techniques are used to estimate air loss due to leaks. One is to determine the compressor capacity required to maintain system pressure when no equipment is being used; another is to determine the rate of pressure drop after compressors are turned off. A leak-reduction program will track the magnitude of leaks over time to determine when it is cost-effective to detect and repair leaks again.

Use Efficient Pneumatic Tools

Air tools are available which use less air: efficient nozzles get the air where you want it, using less air than open tubes or crimped tubes. Squeeze-handles at the nozzle facilitate turning them off when not needed. Solenoid valves and timer controls can provide just the right amount of air for a task. All equipment should have a shutoff valve which is turned off when the equipment is not used. Sensors are available which automatically close a local supply valve when a work area is unoccupied.

By fixing system leaks and replacing

four inefficient blowdown nozzles, a sawmill reduced airflow by 51 percent of system capacity and took a 300-hp compressor off line.

Reduce Pressure Losses

Every bend, joint, connector or system accessory contributes a certain amount of pressure drop due to friction against the moving air.

Line sizing and layout are important design considerations for new construction or system expansions. It may even be cost effective to install larger piping or modify the layout of an existing system. It will save energy and improve overall performance. Valves and quick-disconnect connectors with low pressure drop should be used.

Air coolers and filters used to condition the air cause significant pressure drops. Oversizing them can reduce pressure losses and is typically cost effective, especially in new installations or when being replaced. A regular maintenance program is required to maintain efficiency. Pressure gauges should be installed at the inlet and outlet of major components to measure the pressure drop and indicate when servicing is required.

Dryers to remove moisture from compressed air may use additional electrical energy, or use a significant amount (up to 15 percent) of the compressed air itself. In general, don't dry air more than necessary; drier air typically requires more expensive dryers and operational costs are higher. If part of the plant needs drier air, consider a separate dryer.



Efficient System Pressure Control

Various techniques can control system pressure and demand to improve the overall operating efficiency of the compressors. In addition to reducing the load on compressors, lower pressures will reduce system losses due to the inevitable leaks.

Many pneumatic tools that can operate at lower pressures are often provided full system pressure; regulators can reduce the amount of air used by these tools. Besides using excess air, higher pressure increases equipment wear.

Strategically increasing receiver capacity can help manage system pressure and compressed air demand. Additional storage capacity and pressure controls placed near large, variable compressed air loads can be used to meet peak equipment demands while minimizing the impact on the rest of the system. By improving system efficiency and installing additional storage capacity, one PG&E customer was able to remove a 200-hp compressor, which was on line mainly to handle peak demands.

Users often boost overall system operating pressure when the pressure is inadequate for equipment somewhere in the system. This sometimes makes the problem worse, as leaks and air-tools consume more *cfm* at the higher pressures, and the compressor may no longer have the capacity to meet the demand.

Compressor Management and Control (Produce it efficiently!)

Efficient Management of Multiple

Compressors

Large industrial plants use multiple compressors for reliability and to match variable loads. Since compressors are most efficient at full load, effective control strategies will minimize the time a compressor operates at part load. Typically, the compressor with the worst part-load performance will be the base compressor and that with the best part-load performance will be the swing, or trim compressor.

Often it is possible to improve the sequencing of compressors, especially if they are controlled independently—in such cases all may be operating at part-load, sometimes competing against one another, lowering output while another increases its capacity. Unstable plant pressures are one result.

Sequencing controls are frequently used to assign compressors different fixed pressure levels at which to come on or off line; this causes plant pressure to fluctuate and tends to maintain an average system pressure higher than needed. It is more efficient to use an advanced control system to operate individual compressors at full-load capacity with a single compressor modulated to match plant demand, providing precise pressure regulation. Such controls can also be used to reduce the output pressure when it is known that demand will be low (breaks, lunch, third shift). As a rule of thumb, a pressure reduction of 2 *psi* will save 1 percent of the compressor energy.

Efficient Part-Load Operation

The scheme used to change compressor output may provide another opportunity for savings. Typically, reciprocating



ing compressors have better part-load performance than rotary screw or centrifugal compressors. However, older reciprocating equipment may be inefficient, compared to newer models, and replacement could be cost effective.

To control the quantity of air produced, many rotary screw compressors use an inlet valve known as a modulation control. It is the least efficient method of control; efficiency generally drops dramatically at capacities below 70 percent. Efficiency can be increased significantly by installing controls which unload the compressor below its efficient range. Such controls cost approximately \$500 to install at the factory, and about \$1,000 installed in the field. Adequate receiver capacity is required to avoid short cycling.

Centrifugal compressors, sometimes selected because of their efficiency at full load, are very inefficient at low load. Output is controlled by inlet modulation. Inlet guide vanes can provide greater efficiency than a standard modulating valve. Regardless of the control device, however, when the inlet closes in response to decreasing demand, centrifugal compressors eventually approach a point where airflow becomes unstable, called surge. Because this can cause damage, compressors are typically operated no lower than 60-80 percent of full-load airflow; when demand falls below this, surplus air is blown off—wasted. Modern surge controls allow a greater capacity modulation range before blowoff begins. In a multiple compressor system, the most efficient strategy is to use centrifugal compressors as base compressors.

Other Compressor Efficiency

Improvements

Variable speed controllers can be used on all compressors to provide better part-load efficiency, but are most cost-effectively applied with rotary screw compressors. They currently can operate screw compressors to about 50 percent speed, below which the modulating controls operate. The percentage savings is less than with fans and pumps, so consider the economics carefully. They cost approximately \$150 per horsepower.

For reciprocating and dry screw compressors, use outside air for intake if it is cooler than indoor air. Cooler air is denser and provides more mass for each compression cycle with no more power use. There is no benefit with centrifugal compressors, however.

For new systems and replacements there is an opportunity to select more efficient equipment. For the compressor and the motor which drives it, it is important to consider both the full-load and part-load efficiencies.

Heat Recovery (Recoup your losses!)

Approximately 80-90 percent of the input energy to a compressor goes into raising the temperature of the air. Following are some heat recovery possibilities:

- **Heat from air cooled compressors** can be ducted inside the plant to reduce space heating costs, and deflected outside during the warmer months. Warm air can also be ducted to preheat or dry materials. Approximately 50,000 Btu/h per 100 cfm is available at temperatures of 120° to 200° F.



- **Heat recovered from cooling water** at approximately 120° F can be used to preheat boiler, cleanup or process water. Kits are available to convert air-cooled equipment to water-cooling at a nominal price. In a dirty environment additional benefits include reduced maintenance costs from cleaning cooling fans and radiators, longer compressor life, and extended oil life due to lower oil temperatures.

- **Heat recovered from refrigerated dryers** can be used to reheat compressed air or for other uses.

Heat recovered from compressed air systems is relatively cool and has limited use. Furthermore, it should only be used as supplemental heat, since compressors do not operate all the time. As with any heat recovery opportunity, it is important to find a good fit between the heat source and the heating need.

Applicability

Every plant should have a leak reduction program, and should regulate pressure at air tools. It will not only maintain efficient operation, but will also increase system reliability. In plants with complex compressed air systems, it is important to continually monitor how the air is used, being especially alert to wasteful or inappropriate practices.

Systems with multiple compressors will likely afford significant opportunities to save energy with improved compressor management controls and unload controls.

Heat recovery applications will be found wherever a variable supply of heat can

be used for supplemental space or process heating.

Field Observations to Assess Feasibility

This section suggests some specific things to look for in the field to determine whether efficiency improvements are likely to be cost effective.

Related to Applicability

Most energy savings opportunities will fall in the areas of operations and maintenance practices. If a plant does not have a program to routinely manage leaks, control pressures, and manage compressors, it is likely that many of these improvements can be applied—subject, however, to the priorities of the company.

In some cases specific equipment may be incompatible with some of the improvements described. For example, some compressor manufacturers do not recommend the use of unloading controls on certain models.

For potential heat recovery applications, do not wander too far from the compressor to look for opportunities. Long duct or pipe runs are usually not practical.

Related to Energy Savings

Relatively simple tests can estimate the magnitude of leaks and pressure losses; however, some of these must be done when production is shut down, which may not be feasible in some plants.

The type of compressor and its full- and part-load efficiency are important factors to consider when evaluating energy savings potential. For example, since reciprocating compressors generally have better part-load performance than rotary screw or centrifugal units, unload controls may not be practical.

Related to Implementation Cost

Measures involving sizing or layout of system piping, oversized aftercoolers and filters, or replacement of major equipment will be most cost effective with new systems or plant expansions.

Manufacturing productivity is typically more critical than energy efficiency. Any compressed air efficiency improvements that reduce productivity are not likely to be implemented. But many efficiency improvements will increase the overall performance and reliability of the compressed air system, and this can directly benefit productivity, as well as saving energy. When customers include all the benefits of compressed air system improvements in their analysis, many improvements will be very cost effective.

Estimation of Energy Savings

Estimating energy savings for compressed air system improvements can be complex, but the following guidelines can give the approximate magnitude of savings potential:

- **A reduction of 2 psi** in a typical 100 psi system **saves 1 percent** of compressor energy.

- A typical plant may use **20 percent** of its air output to feed **air leaks**. A leak reduction program that achieves a 50 percent reduction in such losses would save 250 to 500 kWh/hp for reciprocating compressors, and 175 - 325 kWh/hp for rotary screw compressors. (See the technical documentation for the REO program for a complete discussion of the savings calculation.)

Cost and Service Life

Factors That Influence Service Life and First Cost

Measures that decrease run-time and reduce system operating pressure and compressor cycling will improve the service life of a compressor.

The longevity of individual improvements largely depends on the customer's O&M priorities.

Typical Service Life

For leak reduction, PG&E's REO Program assumes a 2-year life.

Operation and Maintenance Requirements

In few industrial systems will maintenance have the impact that it does on compressed air. In fact, most of the improvements discussed in this Note relate to operations and maintenance. Besides items already covered, the following items can help keep a system operating efficiently:

- **Install pressure gauges and thermometers** at critical locations. Take



baseline readings of all pressures and temperatures when the system is operating normally, and repeat at regular intervals. Record compressor pump-up time and system decay rate. These readings can be very useful in the early detection of problems and inefficiencies.

- **Check** operation of controls.
- **Adjust** drive belts and replace if worn or frayed.
- **Clean** intercoolers and aftercoolers.
- **Replace** inlet filters and line filters regularly.
- **Check** moisture traps in receivers, separators, coolers, filters, etc., to be sure they operate properly. When they fail in the open position, it can mean a very costly leak.

Laws, Codes, and Regulations

Compressor performance is typically evaluated using the Power Test Code developed by the American Society of Mechanical Engineers (ASME).

Definitions of Key Terms

- **ACFM:** Actual cubic feet per minute, free air. This is the amount of air at actual conditions prevailing at the compressor inlet.
- **Capacity:** Maximum air flow delivered by the compressor in acfm.

- **CFM:** Cubic feet per minute, a measure of flow rate. Acfm is usually used to express flow rate in compressed air systems. See acfm, scfm.

- **PSI:** Pounds per square inch, a measure of pressure. See psia, psig.

- **PSIA:** Pounds per square inch, absolute. This is the total pressure of air or a gas, including atmospheric pressure. Under standard conditions, atmospheric pressure is 14.7 psi. The absolute pressure of air when compressed to 100 psig is $100 + 14.7 = 114.7$ psia.

- **PSIG:** Pounds per square inch, gauge. This is the pressure above atmospheric pressure.

- **SCFM:** Standard cubic feet per minute. This is the amount of air flow at standard conditions (68°F, 14.7 psia, 36 percent relative humidity).

- **Venturi:** A tapered restriction in a pipe causes air to flow at a higher velocity with reduced pressure. Similarly, a high velocity airstream draws (induces) surrounding air into the stream. Both of these techniques are very inefficient ways to create partial vacuums.

References to More Information

1. Bonneville Power Administration, "Case Studies: Compressed Air System Audits Using AIRMaster," 1997.
2. Compressed Air and Gas Institute, 1230 Keith Building, Cleveland, OH 44115.



3. Electric Power Research Institute, "Compressed Air Handbook, CR-104546," 1994.
4. Rollins, John P., Editor, "Compressed Air and Gas Handbook, Fifth Edition," Prentice Hall PTR, 1989.
5. Talbott, Edwin M., "Compressed Air Systems: A Guidebook on Energy and Cost Savings, Second Edition," The Fairmont Press, Inc., 1993.

Major Organizations

For additional information, contact the Compressed Air and Gas Institute listed in Reference 2.